

Вид сверху

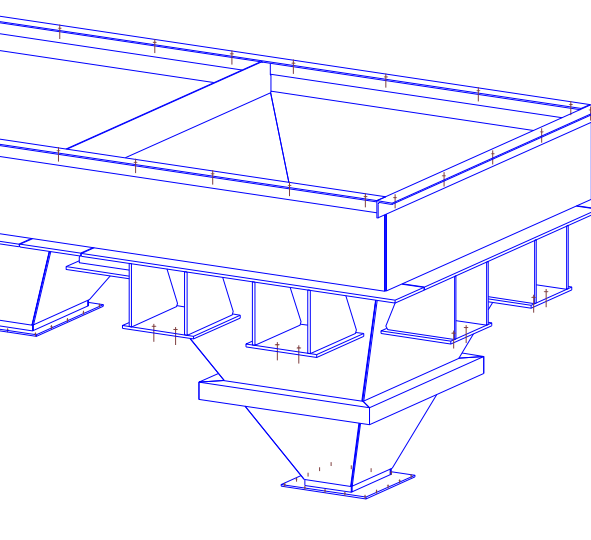
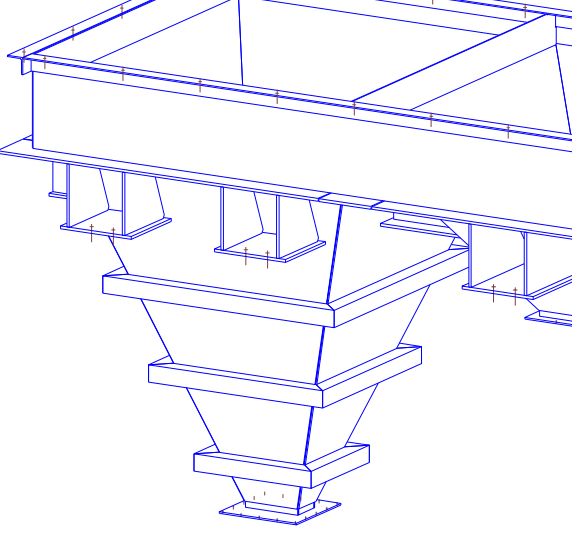
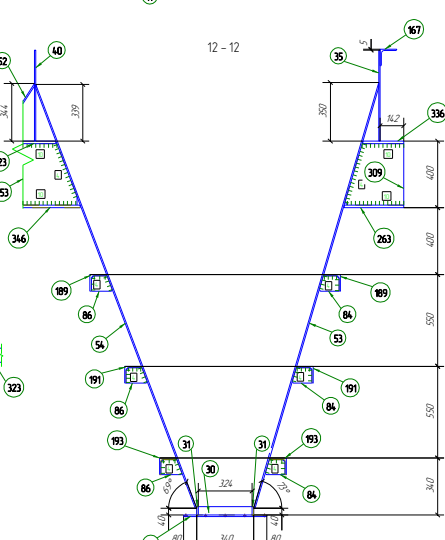
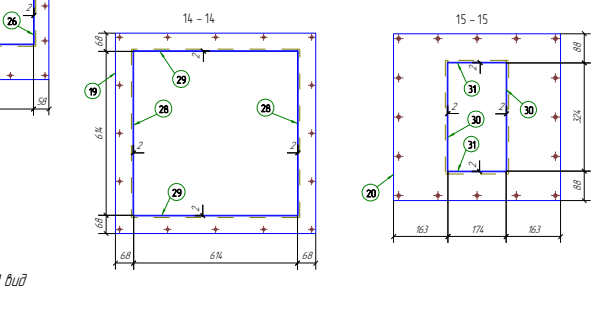
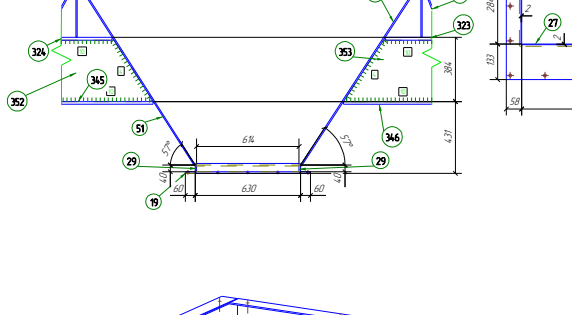
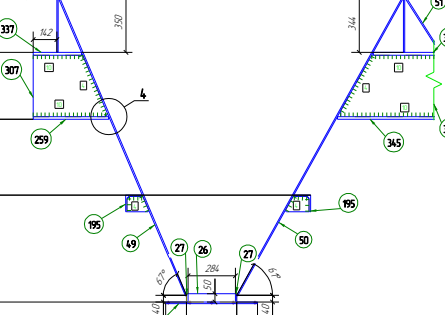
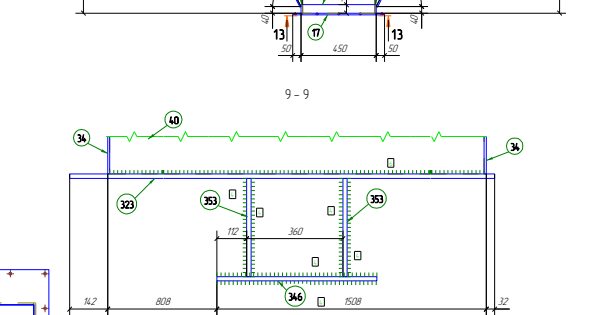
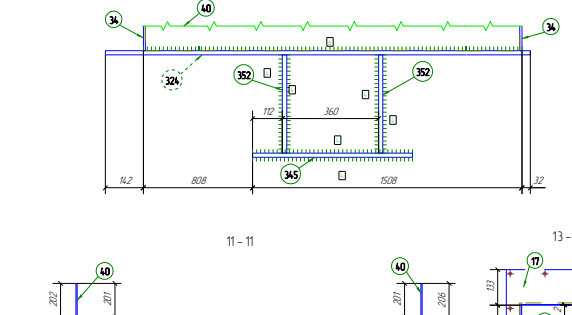
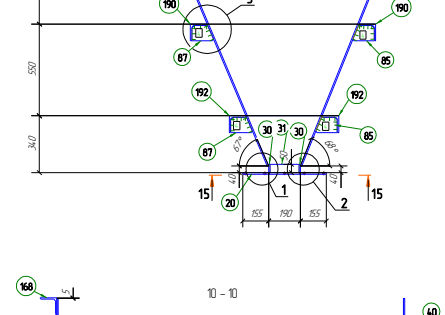
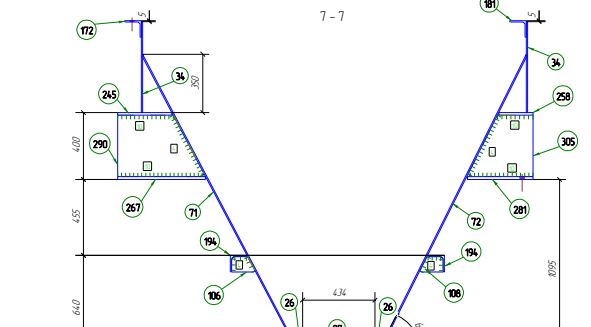
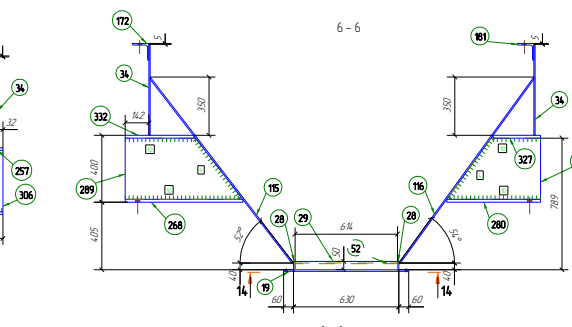
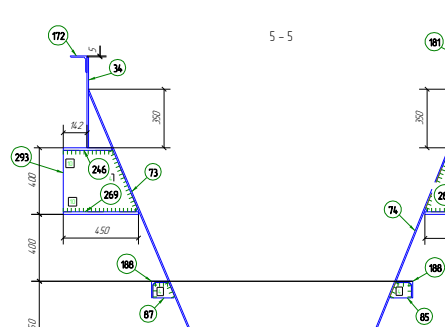
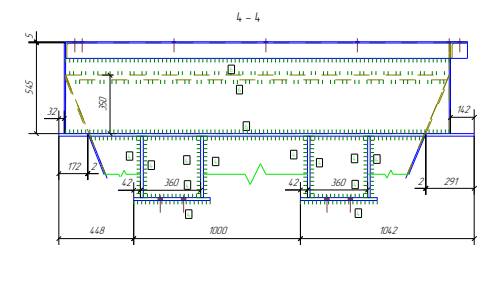
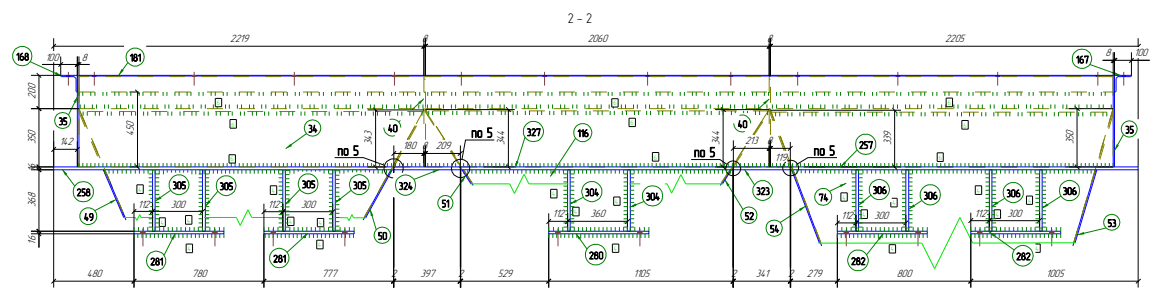
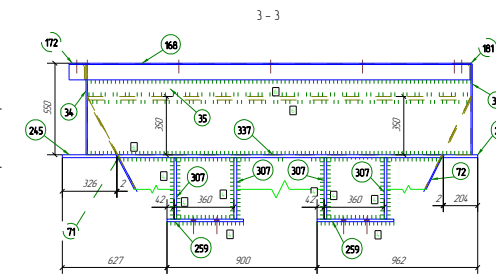
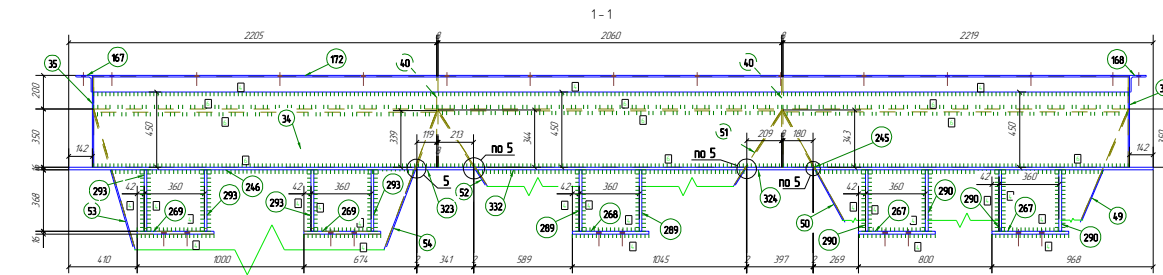
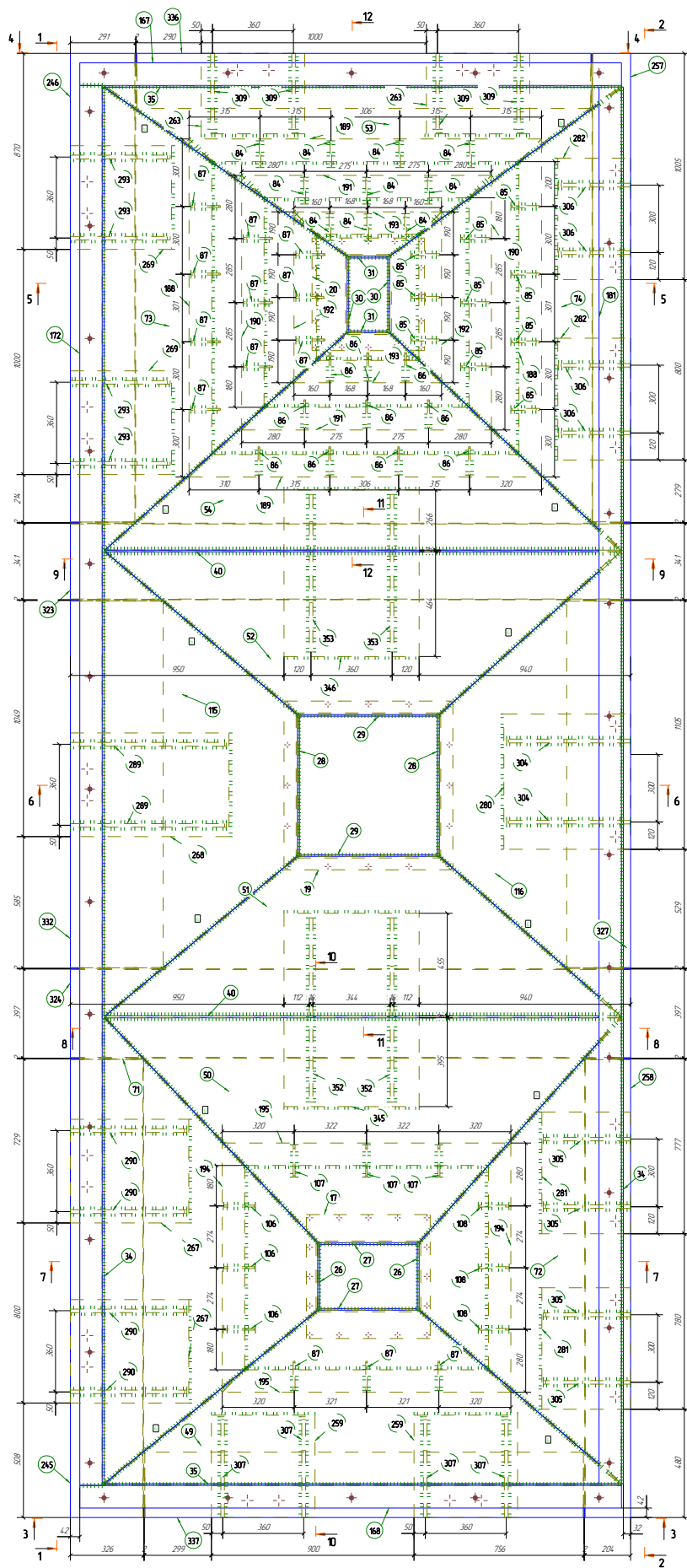

Марка стали	Дет. №	Кол. шт.	Профиль	Длина, мм	Масса, кг		Марка стали	Примечание
					шт	общ		
C245	40	2	-8*545	2300	78.6	157.2	C245	
C245	17	1	-8*550	550	13.8	13.8	C245	
C245	19	1	-8*750	750	16.2	16.2	C245	
C245	20	1	-8*500	500	15.0	15.0	C245	
C245	26	2	-8*50	300	0.9	1.8	C245	
C245	27	2	-8*50	134	1.4	2.8	C245	
C245	28	2	-8*50	630	2.0	4.0	C245	
C245	29	2	-8*50	64	1.9	3.8	C245	
C245	30	2	-8*50	340	1.1	2.2	C245	
C245	31	2	-8*50	174	0.5	1.0	C245	
C245	34	2	-8*545	6200	212.2	424.4	C245	
C245	35	2	-8*545	2300	78.7	157.4	C245	
C245	49	1	-8*186.2	2300	86.1	86.1	C245	
C245	50	1	-8*205.7	2293	76.1	76.1	C245	
C245	51	1	-8*121.6	2291	119.7	119.7	C245	
C245	52	1	-8*122.3	2291	120.5	120.5	C245	
C245	53	1	-8*120.1	2941	205.9	205.9	C245	
C245	54	1	-8*230.0	2992	210.1	210.1	C245	
C245	71	1	-8*86.0	2426	151.0	151.0	C245	
C245	72	1	-8*86.6	2384	149.2	149.2	C245	
C245	73	1	-8*84.3	3045	207.4	207.4	C245	
C245	74	1	-8*84.2	3028	205.9	205.9	C245	
C245	84	10	-8*92	119	0.6	6.0	C245	
C245	85	10	-8*92	129	0.6	6.0	C245	
C245	86	10	-8*92	126	0.6	6.0	C245	
C245	87	10	-8*92	100	0.7	7.1	C245	
C245	88	3	-8*92	140	0.7	2.1	C245	
C245	107	3	-8*92	143	0.7	2.1	C245	
C245	108	3	-8*92	137	0.7	2.1	C245	
C245	115	1	-8*10.8	2060	118.6	118.6	C245	
C245	116	1	-8*10.8	2060	118.0	118.0	C245	
C245	167	1	L200x8	2408	295	295	C245	
C245	168	1	L200x8	2408	295	295	C245	
C245	172	1	L200x8	6276	76.1	76.1	C245	
C245	181	1	L200x8	6200	75.9	75.9	C245	
C245	188	2	L200x8	501	18.4	36.8	C245	
C245	189	2	L200x8	1566	19.2	38.4	C245	
C245	190	2	L200x8	1180	13.8	27.6	C245	
C245	191	2	L200x8	1017	13.6	27.2	C245	
C245	192	2	L200x8	359	9.3	18.6	C245	
C245	193	2	L200x8	656	8.0	16.0	C245	
C245	196	2	L200x8	1017	13.6	27.2	C245	
C245	195	2	L200x8	1283	15.7	31.4	C245	
C245	215	1	-8*326	2037	83.2	83.2	C245	
C245	246	1	-8*291	2084	75.7	75.7	C245	
C245	257	1	-8*172	2084	44.6	44.6	C245	
C245	258	1	-8*204	2037	52.0	52.0	C245	
C245	259	2	-8*454	460	26.2	52.4	C245	
C245	263	2	-8*257	460	20.6	41.2	C245	
C245	267	2	-8*460	527	30.4	60.8	C245	
C245	368	1	-8*460	706	40.8	40.8	C245	
C245	269	2	-8*450	460	26.0	52.0	C245	
C245	280	1	-8*562	600	42.4	42.4	C245	
C245	281	2	-8*194	540	26.7	53.4	C245	
C245	282	2	-8*123	540	21.9	43.8	C245	
C245	289	2	-8*368	694	26.1	52.2	C245	
C245	290	4	-8*368	518	19.9	79.6	C245	
C245	293	4	-8*368	444	17.3	69.2	C245	
C245	304	2	-8*368	551	19.8	39.6	C245	
C245	305	4	-8*368	388	14.1	56.4	C245	
C245	306	4	-8*320	368	11.7	46.8	C245	
C245	307	4	-8*368	447	17.4	69.6	C245	
C245	309	4	-8*352	368	14.0	56.0	C245	
C245	323	7	-8*341	2490	105.8	740.6	C245	
C245	324	1	-8*197	2490	123.5	123.5	C245	
C245	327	1	-8*284	1634	58.2	58.2	C245	
C245	332	1	-8*412	1634	84.5	84.5	C245	
C245	336	1	-8*245	2024	62.1	62.1	C245	
C245	337	1	-8*290	1955	71.1	71.1	C245	
C245	345	1	-8*600	858	64.7	64.7	C245	
C245	346	1	-8*600	739	55.7	55.7	C245	
C245	352	2	-8*368	818	29.4	58.8	C245	
C245	353	2	-8*368	699	25.3	50.6	C245	

Масса нетто металла 10% раскрой, доставка изделий по месту назначения 10%, 2021 кг

Выборка металла на все сварки				Ведомость отработанных элементов			
Профиль	ГОСТ, ТУ	Марка	Масса, кг	Марка	Кол-во, шт	Масса, кг	
						Всех	Итого
-8 Ø мм	99023-74	C245	194.85		1	5262.8	5262.8
-8 Ø мм	99023-74	C245	788.0	ВН-ВБ1-1	1	5262.8	5262.8
-8 Ø мм	99023-74	C245	384.2	Итого		5262.8	5262.8
L200x8	8509-93	C245	434.2				

Ведомость металла			
Наименование	ГОСТ, ТУ	Кол. шт.	Масса, кг
Сварки М20	7788-70	35	84.4
Сварки М20	595-70	70	53.0
Сварки М20	1071-78	70	1.20

208-КМД

Изм.	Кол. экз.	Лист	МД	Лист	Дата
Генератор	Бончук	1/1	1/1	1/1	
Проектировщик	Самойлов	1/1	1/1	1/1	
Разработчик	Бончук	1/1	1/1	1/1	
Специалист	Лавочкин	1/1	1/1	1/1	
Инженер	Прозоров	1/1	1/1	1/1	

Техническое задание на изготовление и доставку элементов и сварки-панелей

Бункер для свежего песка

208-БН4\_ВБ1-1

Разработчик КМД, КМД, ПР, АР  
 Проверка и выделение МД, МД, МД  
 Проверка и выделение МД, МД, МД  
 Проверка и выделение МД, МД, МД